

Iseo Serrature s.p.a  
Via San Girolamo 13  
25055 Pisogne (BS)  
ITALIA  
Tel. +39 0364 8821  
iseo@iseo.com

**ELECTRONIC SUPPORT SERVICE**  
**iseozero1.com**

Non contractual document. Subject to change. Cod. 6000005E00013 - 21/05/2020  
Atlas PLUS Installation Guide (EN) - © 2020 Iseo Serrature S.p.a. - www.iseo.com

### WARNINGS



- Read this manual prior to use the device in order to ensure a safe and proper use.
- Preserve this manual as future reference.
- The installation and maintenance of the device must be carried out by qualified technical staff, adequately trained by ISEO.
- The instructions should be carefully followed during installation. These instructions and any maintenance instructions should be passed on by the installer to the user.
- No modifications of any kind are permitted, except for those described in these instructions.
- The product must be destined only for the use for which it is expressly designed and therefore as web server controller for civil and industrial locations. Any other use is considered improper and dangerous.
- The electrical connection must be made according to the constructor's instructions and respecting the regulations in force.
- For all repairs, exclusively contact a technical assistance center authorized by the constructor.
- Disconnect the power supply before carrying out any technical service that involves opening or accessing the internal parts of the product.
- Dispose of the product separately from household waste, in accordance with local laws and regulations.
- The calculation of the cables section must be performed by qualified staff.
- Max cable length of LOCKBUS channel is 100 mt (sum of all branches).
- Recommended voltage for LOCKBUS channel is 24 VDC.
- In case of power failure the rechargeable battery inside the Atlas ensures power for 30 minutes max.
- Ensure full recharge of the Atlas internal battery by running a full recharge cycle (24 hours), minimum every 6 months.
- It is advisable to provide for an appropriate sectioning, a protection switch upstream of the transformer.
- Atlas earth connection is mandatory.
- Add Surge Protection Devices (SPD) to the mains, upstream the Atlas Master, when connected to Atlas Slaves, Actuators and Readers placed in outside areas of the building (not equipotential zones), according to the Lightning Protection Risk Assessment of your building and current legislations.
- For any technical assistance or repairs, contact only *Iseo Serrature* or an *Iseo Zero1* authorised technical centre.
- *Iseo Zero1* reserves the right, without prior notice, to make all the necessary modifications to the product and to the instruction manual, for quality improvements or manufacturing or marketing needs.



<https://www.iseo.com/it/en/download>

### ATTENTION

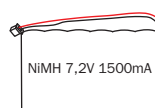

NiMH battery pack  
7,2 V - 1500 mAh



- Risk of explosion if the battery is replaced with an incorrect type. Dispose of used battery according to your local environmental laws and rules.

## 1. TECHNICAL FEATURES

### Communication interfaces:

- 1 Ethernet interface TCP/IP 10/100 base T
- 1 LOCKBUS channel (CHO) to connect Stylos online readers and Actuators (max 8 readers and 8 actuators).
- 2 RS485 channels (CH1/CH2) to connect F9000 online readers (max 1 per channel)
- 1 USB 2.0 Type A
- 1 serial interface (debug)

### Power supply:

- 12÷24 Vdc
- Maximum power consumption 10W (with no connected devices)

### Internal Backup battery:

- 1500mAh (7,2Vdc) NiMH battery pack
- Estimated backup time: 30 minutes

### CPU and memory:

- ARM 9 based CPU module
- 800MHz CPU clock
- 512MB Flash memory
- 64MB SDRAM
- 8GB Micro-SD

### Operative system:

- Linux

### Push buttons:

- S1 Reset (to manually reboot the Atlas)
- S2 Wake-up (to manually start the Atlas when OFF)
- S3 Switch off (to manually switch off the Atlas)

### Housing:

- Desktop housing (black color)
- L x W x H = 167 x 110 x 53 mm

### Environmental characteristics:

- Operating temperature: 0°C ÷ +50°C
- Storage temperature: -25°C ÷ +75°C

### Conformity certifications:

- 2014/53/EU RED
- RoHS (electrical and electronic equipment).
- References standards: EN301 489-1, EN301 489-17, EN330 440, EN60950-1, EN62209-2.
- For details see Declarations of Conformity available at [iseo.com](http://iseo.com) website (download area).

### Package contents:

- 1 Atlas Server for RFID and F9000 ON-LINE and OFF-LINE devices, with connectors.
- 1 Power supply unit 230Vac/24Vdc - 1,65A (35W)
- Installation guide.

## 2. ATLAS OVERVIEW

Connect to **192.168.0.184** from *Google Chrome*, *Microsoft Edge* or *Apple Safari* Internet browser.

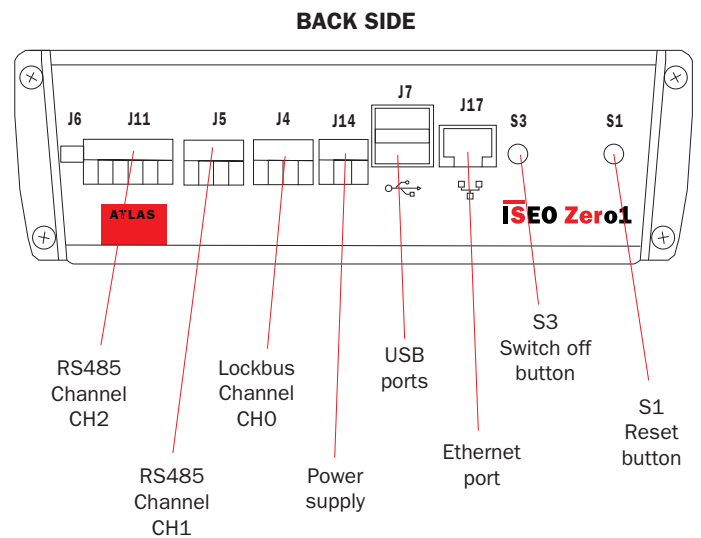
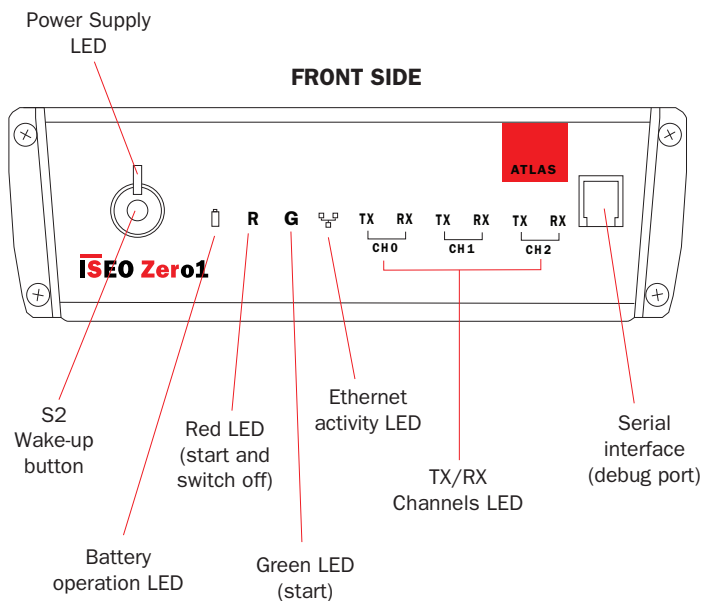

3. V364 RFID SYSTEM WIRING:  
2 DOORS CONTROLLER CONNECTION EXAMPLE

BACK SIDE

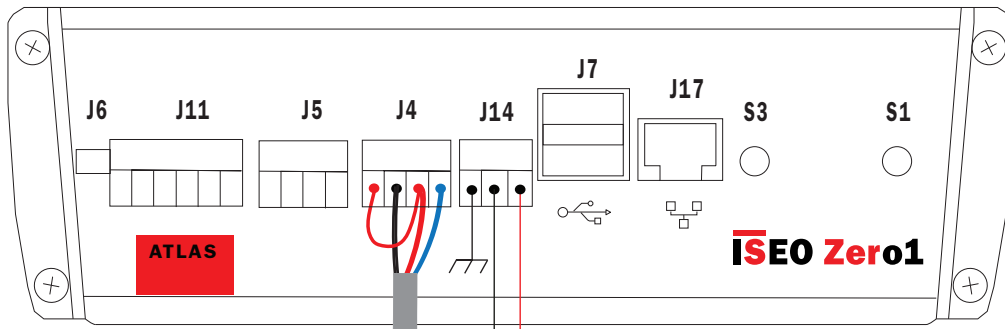

- Suggested configuration for 2 doors controller: max 4 Stylos readers.
- Devices consumption:
  - ATLAS = 10 W
  - Stylos = 3W
  - Actuator = 3W
- Wirings also applies to Atlas Standard

DOOR 1

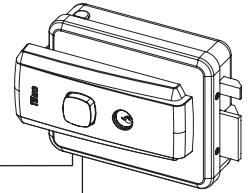

DOOR 1  
(Stylos cod.5E1310126)

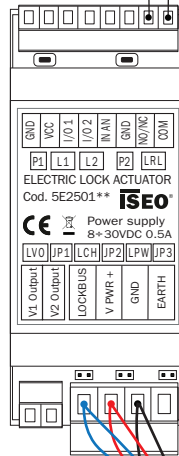
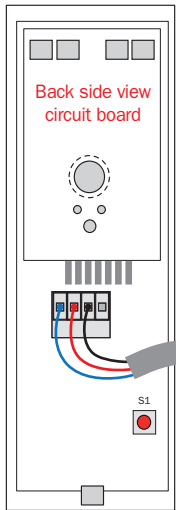

DOOR 1  
(Actuator cod.5E2501)



For the Stylos address configuration refer to the Stylos Installation Guide, available at: [iseo.com](http://iseo.com).

DOOR 2

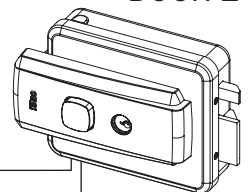

DOOR 2  
(Stylos cod.5E1310126)

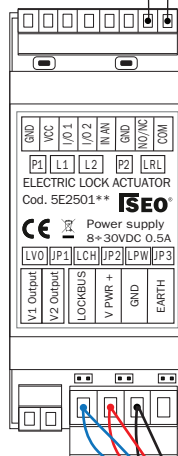
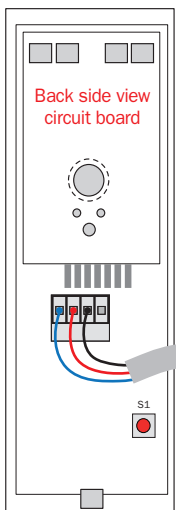

DOOR 2  
(Actuator cod.5E2501)

12 VAC

WIRING SPECIFICATIONS

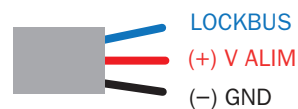

- Cable 3 x 0,75mm<sup>2</sup> - AWG 18 (the calculation of the cables section must be verified by qualified staff).
- Total LOCKBUS channel cable length (sum of all branches): MAX 100mt.
- Conductor capacitance < 100pF/m.
- Conductors electrical resistance max 90 ohm/Km.

Wires colors reported in the wiring diagrams are just an example.

4. V364 F9000 SYSTEM WIRING:  
2 DOORS CONTROLLER CONNECTION EXAMPLE



- Maximum number of devices that can be connected to the RS485 channel = 1 (per channel).
- Devices consumption:
  - ATLAS = 10 W
  - F9000 reader= 1W
  - Actuator = 3W
- Wirings also applies to Atlas Standard

BACK SIDE

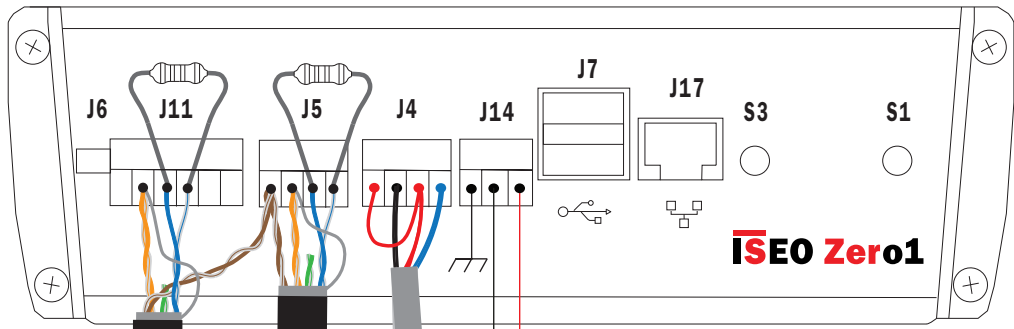

DOOR 1

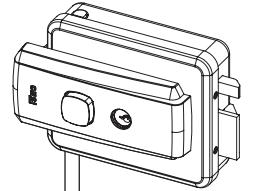

Power supply unit:  
24 VDC - 1,65 A  
(35 W)

12 VAC

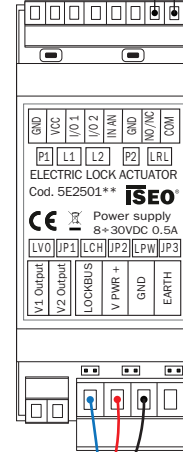

DOOR 1  
(Actuator cod.5E2501)

DOOR 2

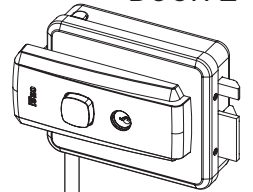

12 VAC

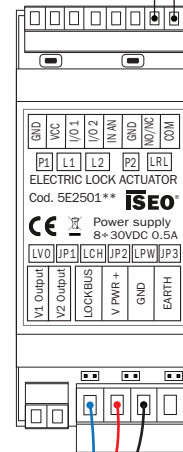

DOOR 2  
(Actuator cod.5E2501)

DOOR 2  
(F9000 reader  
cod.E032\*\*)

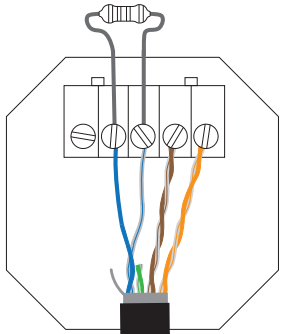

DOOR 1  
(F9000 Reader  
cod.E032\*\*)

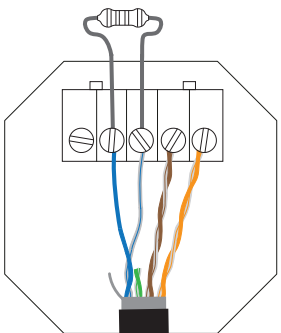

WIRING SPECIFICATION

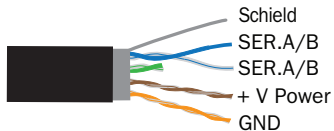

- Use an Ethernet cable FTP AWG24 CAT5E (and above).
- Maximum Ethernet cable length between Atlas and F9000 Reder: 500mt.
- Connect a resistance value of 120 ohm (1/4W), on both Atlas and F9000 Reader sides, as shown in the scheme.
- Conductor capacitance < 100pF/m.
- Conductors electrical resistance max 90 ohm/Km.

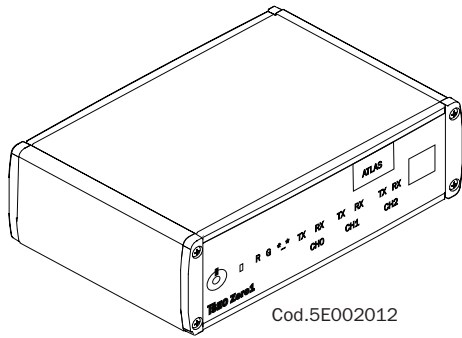

Cod.5E002012



Iseo Serrature s.p.a  
Via San Girolamo 13  
25055 Pisogne (BS)  
ITALIA  
Tel. +39 0364 8821  
iseo@iseo.com

**ELECTRONIC SUPPORT SERVICE**  
**iseozero1.com**

Non contractual document. Subject to change. Cod. 6000005E00013 - 21/05/2020  
Atlas PLUS Installation Guide (IT) - © 2020 Iseo Serrature S.p.a. - www.iseo.com

### AVVERTENZE



<https://www.iseo.com/it/it/download>



- Si prega di leggere questo manuale prima di utilizzare il dispositivo per garantire un uso sicuro e corretto.
- Conserva questo manuale come riferimento futuro.
- L'installazione e la manutenzione di questo dispositivo deve essere effettuata da personale tecnico qualificato, adeguatamente formato da ISEO.
- Le istruzioni devono essere attentamente seguite durante l'installazione. Queste istruzioni e qualsiasi altra istruzione di manutenzione deve essere trasferita dall'installatore all'utilizzatore.
- Nessuna modifica di alcun tipo è permessa, ad eccezione di quelle descritte in queste istruzioni.
- Il prodotto deve essere destinato esclusivamente all'uso per il quale è espressamente progettato e quindi come controller di server Web per sedi civili e industriali. Ogni altro uso è considerato improprio e pericoloso.
- Il collegamento elettrico deve essere eseguito secondo le leggi vigenti da personale qualificato.
- Per tutte le riparazioni contattare esclusivamente i centri di assistenza tecnica autorizzati dal costruttore.
- Scollegare l'alimentazione prima di eseguire qualsiasi servizio tecnico che comporti l'apertura o l'accesso alle parti interne del prodotto.
- Smaltire il prodotto separatamente dai rifiuti domestici, in conformità con le leggi e i regolamenti locali.
- Il calcolo della sezione dei cavi deve essere effettuato da personale qualificato.
- La massima lunghezza del cavo del canale LOCKBUS è 100 mt (somma di tutti i rami).
- Il voltaggio consigliato per il canale LOCKBUS è 24 VDC.
- In caso di interruzione di corrente la batteria ricaricabile all'interno dell'Atlas garantisce l'alimentazione per massimo 30 minuti.
- Garantire la ricarica completa della batteria interna dell'Atlas eseguendo un ciclo di ricarica completo (24 ore), minimo ogni 6 mesi.
- Per una corretta protezione dell'impianto elettrico, è consigliabile prevedere un interruttore di protezione a monte del trasformatore.
- La connessione a terra dell'Atlas è obbligatoria.
- Se l'Atlas Master è collegato ad Atlas Slave, Attuatori e Lettori, collocati in aree esterne all'edificio principale (zone non equipotenziali), aggiungere alla rete elettrica, a monte dell'Atlas Master, dei Dispositivi di Protezione da Sovratensioni (Surge Protection Devices - SPD). Questo in ottemperanza alla Valutazione del Rischio di Protezione contro i Fulmini del tuo edificio secondo le legislazioni vigenti.
- Per assistenza tecnica o riparazioni, contattare esclusivamente *Iseo Serrature* o un centro tecnico autorizzato *Iseo Zero1*.
- *Iseo Zero1* si riserva il diritto, senza preavviso, di apportare tutte le modifiche necessarie al prodotto e al manuale di istruzioni, per miglioramenti di qualità o necessità di produzione o di marketing.

### ATTENTION

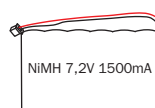

NiMH battery pack  
7,2 V - 1500 mAh



- Pericolo d'esplosione se la batteria è sostituita con altra di tipo errato. Smaltire le batterie esaurite in base alle leggi e alle norme ambientali locali.

## 1. CARATTERISTICHE TECNICHE

### Interfacce di comunicazione:

- 1 interfaccia Ethernet TCP/IP 10/100 base T
- 1 canale LOCKBUS (CHO) per connettere lettori Stylos online e Attuatori (max 8 lettori e 8 lettori).
- 2 canali RS485 (CH1/CH2) per connettere i lettori F9000 online (max 1 per canale)
- 2 USB 2.0 Tipo A
- 1 interfaccia seriale (debug)

### Alimentazione:

- 12÷24 Vdc
- Potenza massima assorbita 10W (senza dispositivi collegati).

### Batteria di backup interna:

- Pacco batterie 1500mAh (7,2Vdc) NiMH
- Tempo di backup stimato: 30 minuti

### CPU e memoria:

- Modulo CPU ARM 9
- Orologio 800MHz CPU
- Flash memory 512MB
- 64MB SDRAM
- 8GB Micro-SD

### Sistema operativo:

- Linux

### Pulsanti:

- S1 Reset (per effettuare manualmente il reboot dell'Atlas)
- S2 Wake-up (per accendere manualmente l'Atlas quando è spento)
- S3 Switch off (per spegnere manualmente l'Atlas)

### Scatola:

- Scatola per appoggio a banco (colore nero)
- L x L x A = 167 x 110 x 53 mm

### Caratteristiche ambientali:

- Temperatura di operatività: 0°C ÷ +50°C
- Temperatura di stoccaggio: -25°C ÷ +75°C

### Certificazioni di conformità:

- 2014/53/EU RED
- RoHS (apparecchiature elettriche ed elettroniche).
- Standard di riferimento: EN301 489-1, EN301 489-17, EN330 440, EN60950-1, EN62209-2.
- Per dettagli consulta le Dichiarazioni di Conformità disponibili sul sito web [iseo.com](http://iseo.com) (area download).

### Contenuto della confezione:

- 1 Atlas Plus server per dispositivi RFID e F9000 ON-LINE e OFF-LINE, con i connettori.
- Alimentatore 230Vac/24 Vdc - 1,65A (35W)
- Guida Installazione.

## 2. ATLAS VISTA GENERALE

Connettersi a **192.168.0.184** da browser Internet Google Chrome, Microsoft Edge o Apple Safari.

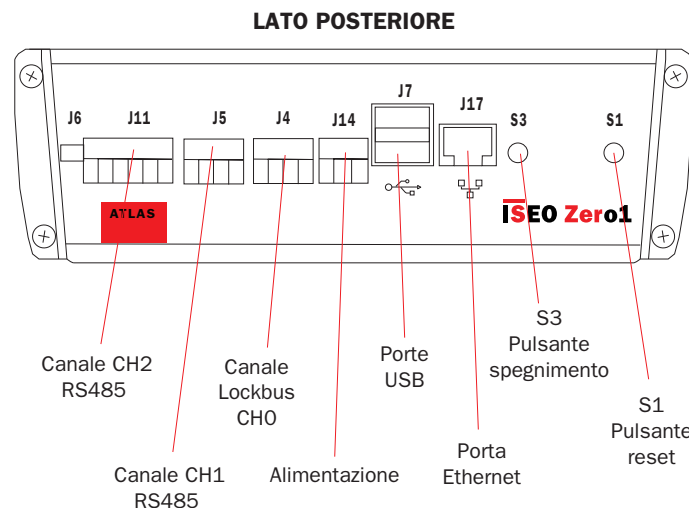
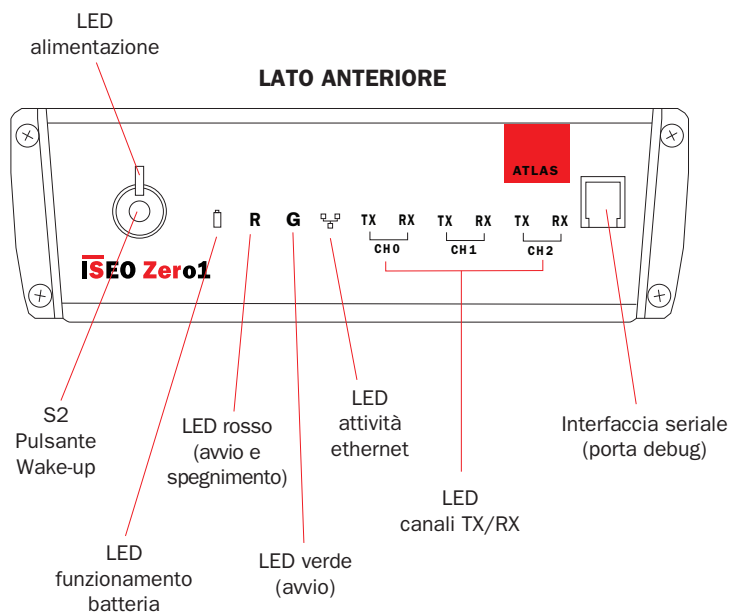

3. CABLAGGIO SISTEMA V364 RFID:  
ESEMPIO DI CONNESSIONE PER LA GESTIONE DI 2 PORTE

LATO POSTERIORE

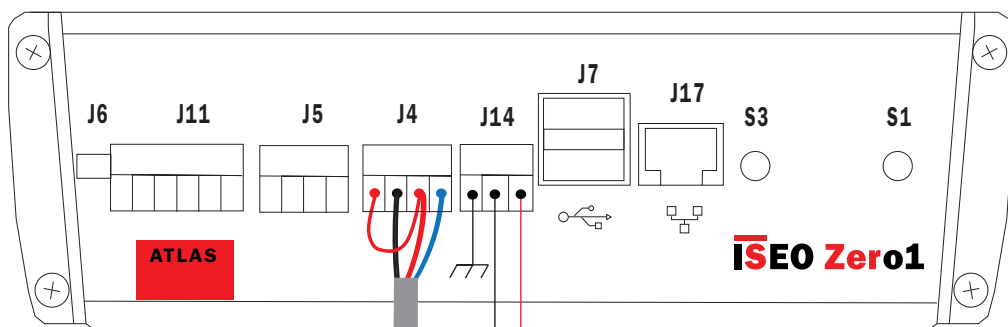

- Configurazione suggerita per la gestione di 2 porte: max 4 lettori Stylos.
- Consumi dispositivi:
  - ATLAS = 10 W
  - Stylos = 3W
  - Attuatore = 3W
- I cablaggi si applicano anche all'Atlas Standard

Unità di alimentazione:  
24 VDC - 1,65 A (35 W)

PORTA 1

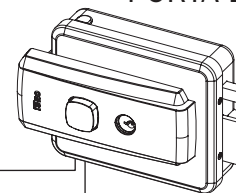

PORTA 1  
(Stylos cod.5E1310126)

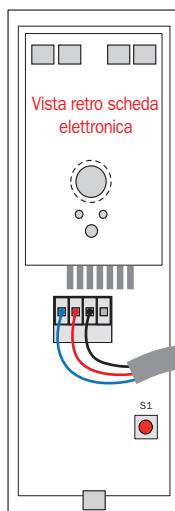

PORTA 1  
(Attuatore  
cod.5E2501)

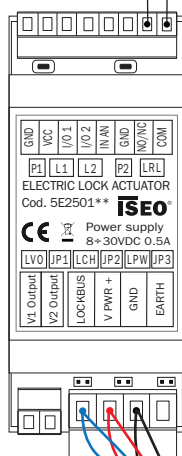

Per la configurazione degli indirizzi dello Stylos, consultare la Guida Installazione Stylos al sito: [iseo.com](http://iseo.com).

PORTA 2

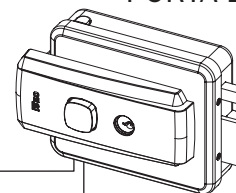

PORTA 2  
(Stylos cod.5E1310126)

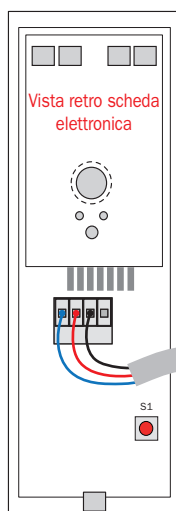

PORTA 2  
(Attuatore  
cod.5E2501)

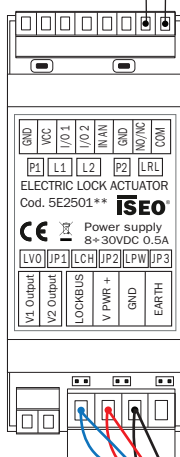

SPECIFICHE CABLAGGI

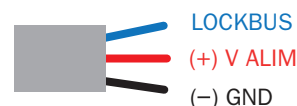

- Cavo allarme 3 x 0,75mm<sup>2</sup>- AWG 18 (il calcolo della sezione dei cavi deve essere verificato da personale qualificato).
- Lunghezza totale dei cavi collegati al canale LOCKBUS (somma di tutti i rami): MAX 100 mt.
- Capacità conduttore < 100 pF/m.
- Resistenza elettrica del conduttore max 90 ohm/Km.

*I colori dei cablaggi riportati negli schemi elettrici sono solo un esempio.*

4. CABLAGGIO SISTEMA V364 F9000:  
ESEMPIO DI CONNESSIONE PER LA GESTIONE DI 2 PORTE



- Numero massimo di dispositivi collegabili ai canali RS485 = 1 (per canale).
- Consumi dispositivi:
  - ATLAS = 10 W
  - Lettore F9000 = 1W
  - Attuatore = 3W
- I cablaggi si applicano anche all'Atlas Standard

LATO POSTERIORE

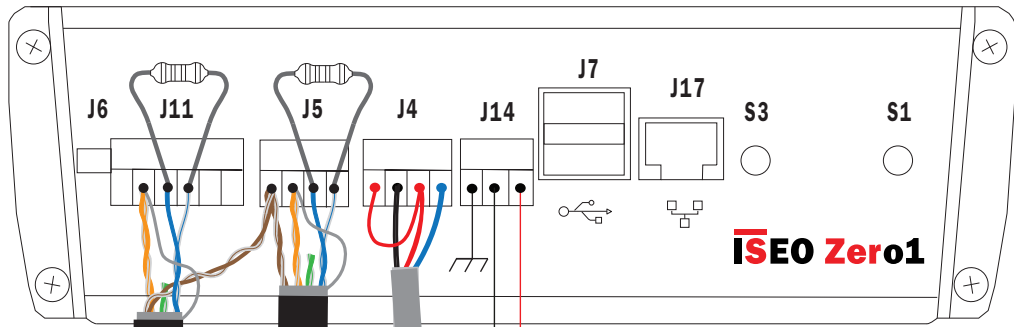

PORTA 2  
(Lettore F9000  
cod.E032\*\*)

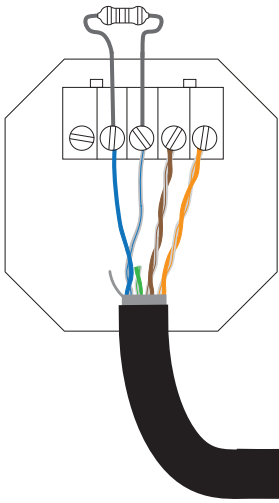

PORTA 1  
(Lettore F9000  
cod.E032\*\*)

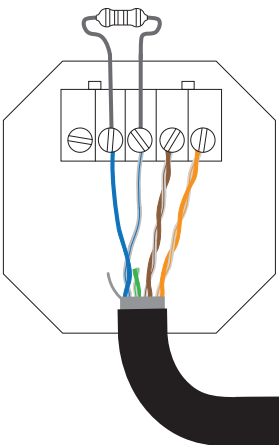

Unità di alimentazione:  
24 VDC - 1,65 A  
(35 W)



12 VAC

PORTA 1  
(Attuatore cod.5E2501)

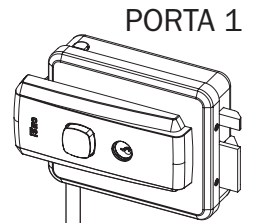

PORTA 2

12 VAC

PORTA 2  
(Attuatore cod.5E2501)

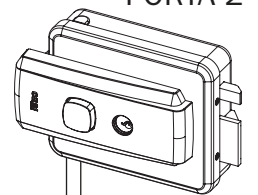

SPECIFICHE CABLAGGI

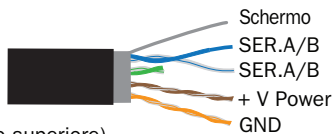

- Cavo Ethernet FTP AWG24 CAT5E (o superiore).
- Massima lunghezza del cavo Ethernet tra Atlas e Lettore F9000: 500 mt.
- Collegare una resistenza da 120 ohm (1/4 W), sia lato Atlas che lato Lettore F9000, come mostrato nello schema.
- Capacità conduttore < 100 pF/m.
- Resistenza elettrica del conduttore max 90 ohm/Km.

I colori dei cablaggi riportati negli schemi elettrici sono solo un esempio.



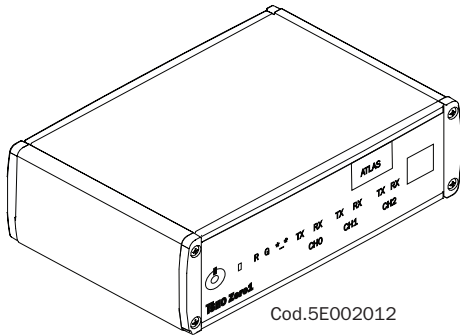

Cod.5E002012



Iseo Serrature s.p.a  
Via San Girolamo 13  
25055 Pisogne (BS)  
ITALIA  
Tel. +39 0364 8821  
iseo@iseo.com

**ELECTRONIC SUPPORT SERVICE**  
**iseozero1.com**

Kein rechtsverbindliches Dokument. Änderungen und Irrtümer vorbehalten. Cod. 6000005E00013 - 21/05/2020  
Atlas PLUS Installationsanleitung (DE) - © 2020 Iseo Serrature S.p.a. - www.iseo.com

### HINWEISE



- Lesen Sie diese Anleitung vor Benutzung des Gerätes, um den sachgemäßen Umgang zu gewährleisten.
- Bewahren Sie diese Anleitung als künftige Referenz auf.
- Die Installation und Wartung des Gerätes muss durch qualifiziertes, von ISEO entsprechend geschultes technisches Personal erfolgen.
- Folgen Sie bei der Installation sorgfältig der Anleitung. Anleitung und ggf. Wartungsanweisungen sollten vom Installateur an den Nutzer weitergegeben werden.
- Änderungen jeglicher Art, außer der in dieser Anleitung beschriebener, sind nicht erlaubt.
- Das Produkt darf nur zu dem Zweck verwendet werden, für den es konzipiert wurde, anderweitiger Gebrauch gilt als unsachgemäß und ist gefährlich.
- Die elektrischen Anschlüsse sind entsprechend den Anweisungen in dieser Anleitung vorzunehmen und müssen den geltenden Vorschriften entsprechen.
- Wenden Sie sich für alle Reparaturen ausschließlich an einen vom Hersteller autorisierten technischen Fachhändler.
- Unterbrechen Sie die Stromzufuhr, bevor Sie technische Services durchführen, die das Öffnen oder den Zugang zu den inneren Teilen des Produkts beinhaltet.
- Entsorgen Sie das Produkt getrennt vom Hausmüll, in Übereinstimmung mit den örtlichen Gesetzen und Vorschriften.
- Die Berechnung des Kabelquerschnitts muss von qualifiziertem Personal durchgeführt werden.
- Gesamte LOCKBUS Kanal Kabellänge beträgt 100 Meter (Summe aller Zweige).
- Die empfohlene Spannung für den LOCKBUS-Kanal beträgt 24 VDC.
- Im Falle eines Stromausfalls gewährleisten der Stützakku im Inneren des Atlas die Stromversorgung für maximal 30 Minuten.
- Stellen Sie sicher, dass der interne Akku des Atlas mindestens alle 6 Monate durch einen vollständigen Ladezyklus (24 Stunden) aufgeladen wird.
- Es ist ratsam, für eine entsprechende Trennung, einen Schutzscharter vor der Spannungsversorgung zu verbauen.
- Eine Atlas-Erdungsverbindung ist unbedingt erforderlich.
- Verwenden Sie vor dem Atlas Master Überspannungsschutzgeräte (SPD), wenn dieser mit Atlas Slaves, Aktuatoren und Lesern verbunden wird, die im Außenbereich (mit Potentialdifferenz) platziert sind, entsprechend der Blitzschutz-Risikobewertung Ihres Gebäudes und der aktuellen Gesetzgebung.
- Für technische Unterstützung oder Reparaturen wenden Sie sich nur an Iseo Serrature oder an einen von Iseo Zero1 autorisierten Fachhändler.
- Iseo Zero1 behält sich das Recht vor, ohne Vorankündigung alle notwendigen Änderungen am Produkt und an der Installationsanleitung vorzunehmen, um Qualitätsverbesserungen oder Herstellungs- oder Marketinganforderungen zu erfüllen.

### AUFMERKSAMKEIT

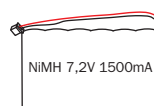

NiMH battery pack  
7,2 V - 1500 mAh



- Es besteht Explosionsgefahr, wenn die Batterie mit einem falschen Typersetzt wird. Entsorgen Sie verbrauchte Batterien umgehend und im Einklang mit den örtlichen Umweltgesetzen und Richtlinien.

## 1. TECHNISCHE DATEN

### Kommunikationsschnittstellen:

- 1 Ethernet Schnittstelle TCP/IP 10/100 base T
- 1 LOCKBUS Kanal (CHO) zum Anschluss von Stylos Online Lesern und Aktuatoren (max. 8 Lesern und 8 Aktuatoren).
- 2 RS485 Kanäle (CH1/CH2) zum Anschluss von F9000 Online Lesern (max 1 pro Kanal)
- 1 USB 2.0 Typ A
- 1 Serielle Schnittstelle (debug)

### Spannungsversorgung:

- 12 bis 24 V DC
- Maximaler Verbrauch 10 W (wenn keine weiteren Geräte angeschlossen sind)

### Interne Stützbatterie:

- 1500mAh (7,2Vdc) NiMH Batterie
- Geschätzte Überbrückungszeit: 30 Minuten

### CPU and Speicher:

- ARM 9 basierendes CPU Modul
- 800MHz CPU Takt
- 512MB Flash Speicher
- 64MB SDRAM
- 8GB Micro-SD

### Betriebssystem:

- Linux

### Funktionstasten:

- S1 Neustart (zum manuellen neu starten des Atlas)
- S2 Einschalten (zum manuellen Einschalten des Atlas)
- S3 Ausschalten (zum manuellen Ausschalten des Atlas)

### Gehäuse:

- Tischgehäuse (schwarz)
- L x B x H = 167 x 53 x 110 mm

### Umweltbedingungen:

- Betriebstemperatur: 0 °C ÷ +50 °C;
- Lagertemperatur: -25 °C ÷ +75 °C.

### Konformitätserklärungen:

- 2014/53/EU RED
- RoHS (elektrische und elektronische Geräte).
- Normen: EN301 489-1, EN301 489-17, EN330 440, EN60950-1, EN62209-2.
- Weitere Details zu Konformitätserklärungen sind unter [www.iseo.com](http://www.iseo.com) verfügbar.

### Verpackungsinhalt:

- 1 Atlas Plus Controller für RFID und F9000 ONLINE und OFFLINE Geräte, inkl. Steckverbindern.
- 1 Netzteil 230Vac/24Vdc - 1,65A (35W).
- Installationsanleitung.

## 2. ÜBERSICHT

Verbinden zu **192.168.0.184** mit Google Chrome, Microsoft Edge oder Apple Safari Internet Browser.

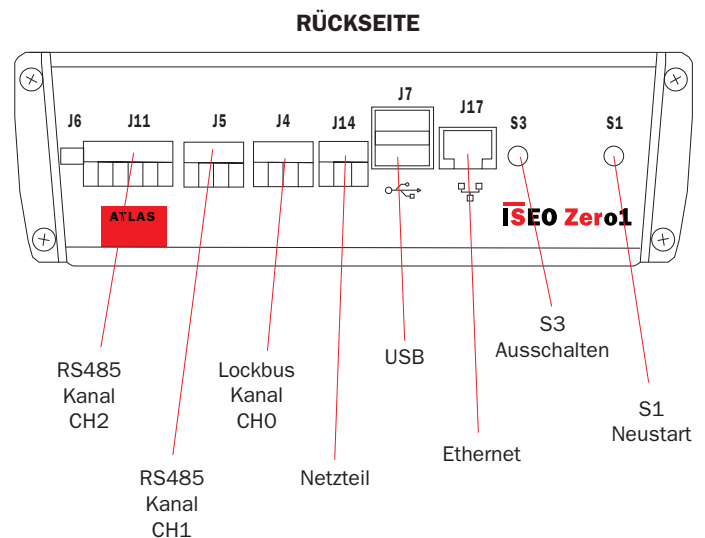
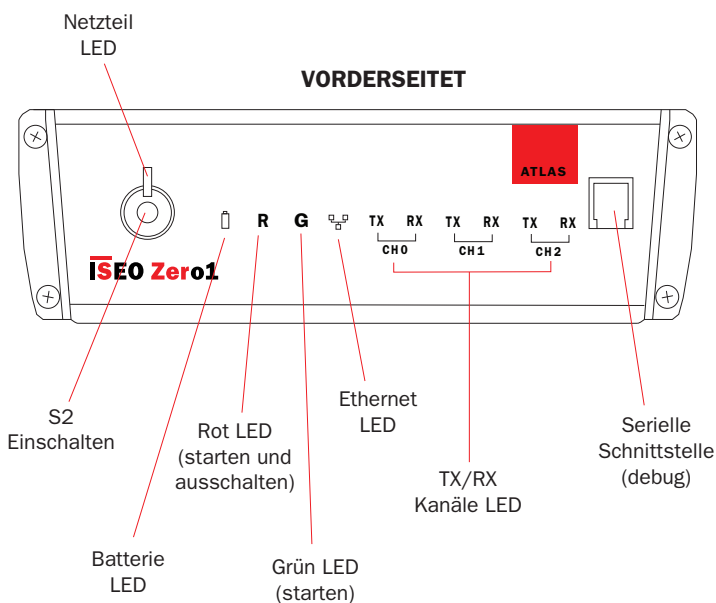

3. V364 RFID SYSTEM VERKABELUNG:  
2 TÜREN VERSCHALTUNGSBEISPIEL

RÜCKSEITE

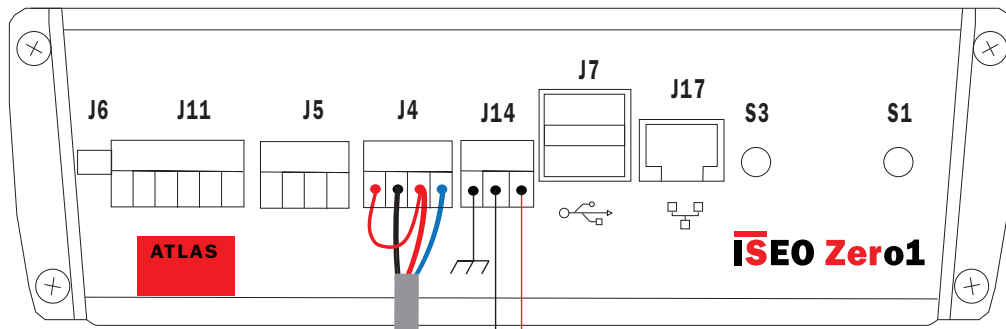

- Empfohlene Konfiguration für 2 Türen Controller: max. 4 Stylos Leser.
- Geräte-Verbrauch:
  - ATLAS = 10 W
  - Stylos = 3W
  - Aktuator = 3W
- Die Verkabelung gilt auch für Atlas Standard

Spannungsversorgung:  
24 VDC - 1,65 A (35 W)

TÜR 1  
(Stylos cod.5E1310126)

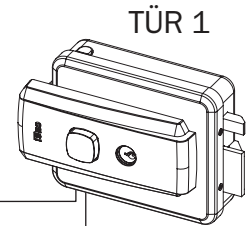
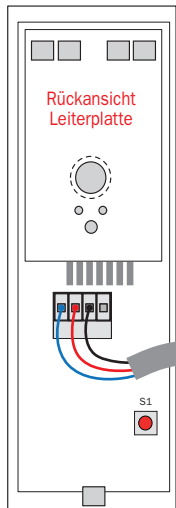

12 VAC

TÜR 1  
(Aktuator  
cod.5E2501)

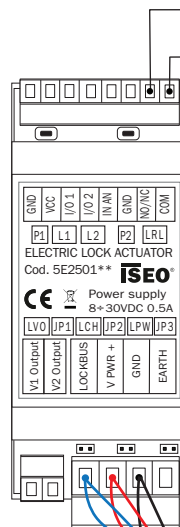

Die Stylos-Adresskonfiguration finden Sie im Stylos-Installationshandbuch, verfügbar unter: [iseo.com](http://iseo.com).

TÜR 2  
(Stylos cod.5E1310126)

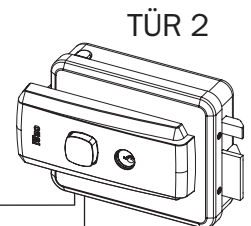
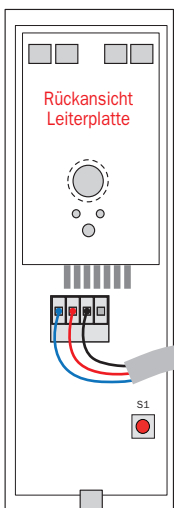

12 VAC

TÜR 2  
(Aktuator  
cod.5E2501)

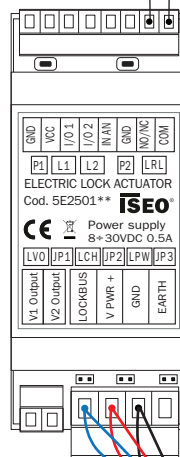

KABEL-SPEZIFIKATIONEN

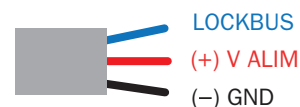

- Kabel 3 x 0,75mm<sup>2</sup> - AWG 18 (die Berechnung des Kabel querschnitts muss durch qualifiziertes Personal erfolgen).
- Gesamte LOCKBUS Kanal Kabellänge (Summe aller Zweige): Maximal 100 Meter
- Leitungskapazität < 100pF/m.
- Elektrischer Leitungswiderstand max. 90 Ohm/Km.

In Schaltplänen dargestellte Farben der Drähte sind nur ein Beispiel.

#### 4. V364 F9000 SYSTEM VERKABELUNG: 2 TÜREN VERSCHALTUNGSBEISPIEL



- Maximale Anzahl von Geräten, die an den RS485-Kanal angeschlossen werden können = 1 (pro Kanal).
- Geräte-Verbrauch:
  - ATLAS = 10 W
  - F9000 Leser = 1W
  - Aktuator = 3W
- Die Verkabelung gilt auch für Atlas Standard

### RÜCKSEITE

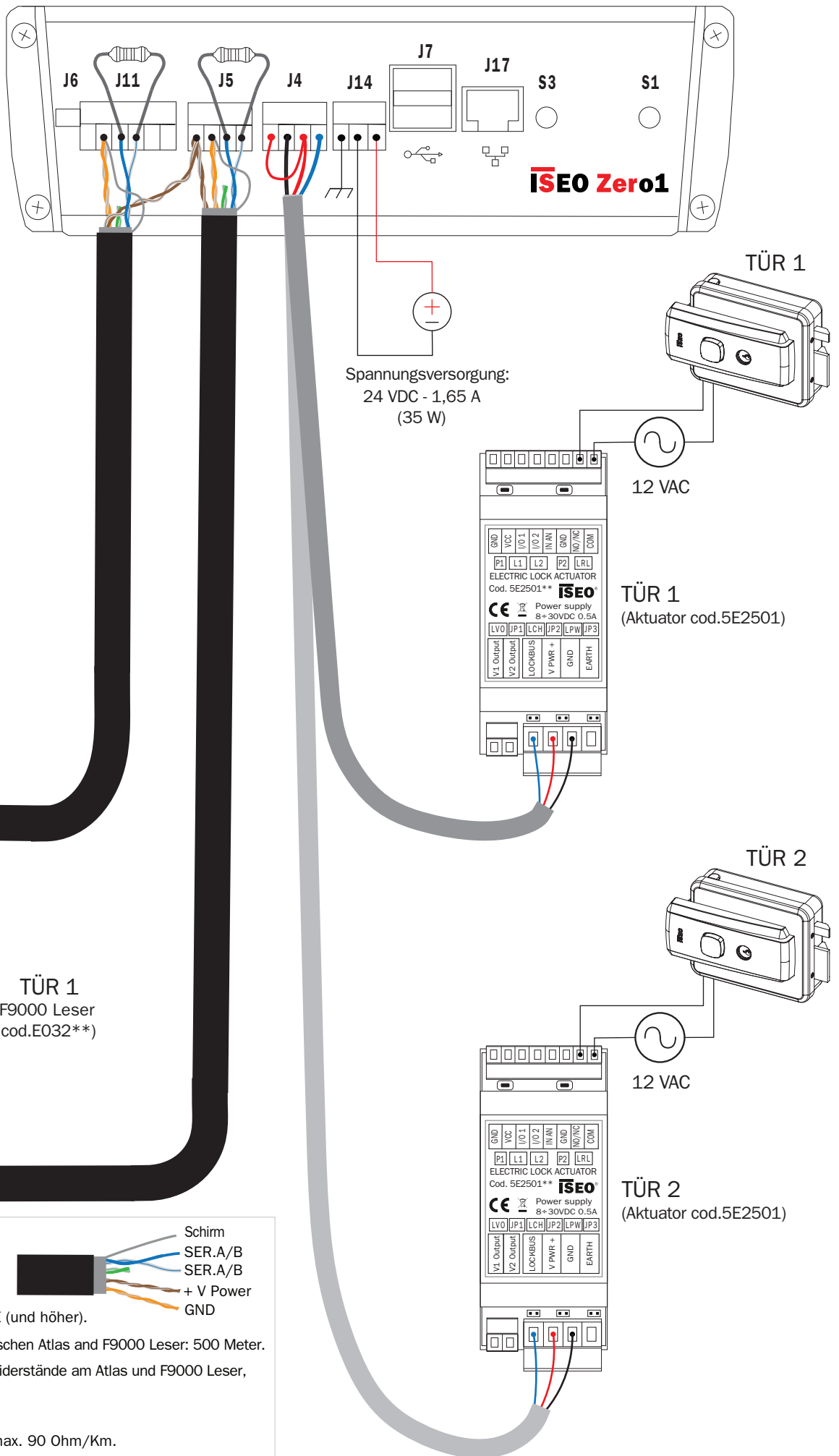

TÜR 2  
(F9000 Leser  
cod.E032\*\*)

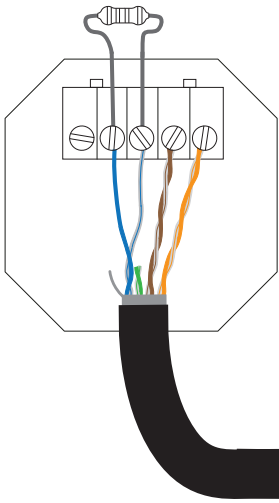

TÜR 1  
(F9000 Leser  
cod.E032\*\*)

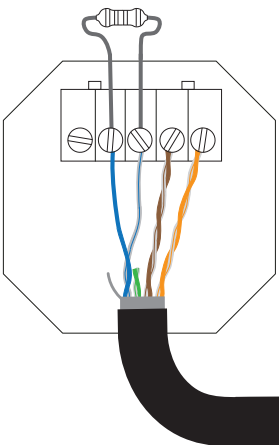

#### KABEL-SPEZIFIKATIONEN

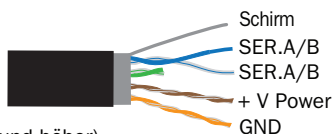

- Netzwerkkabel FTP AWG24 CAT5E (und höher).
- Maximale Netzwerkkabel-Länge zwischen Atlas und F9000 Leser: 500 Meter.
- Verwenden Sie 120 Ohm (1/4W) Widerstände am Atlas und F9000 Leser, wie im Schema dargestellt.
- Leitungskapazität < 100pF/m.
- Elektrischer Leitungswiderstand max. 90 Ohm/Km.

In Schaltplänen dargestellte Farben der Drähte sind nur ein Beispiel.

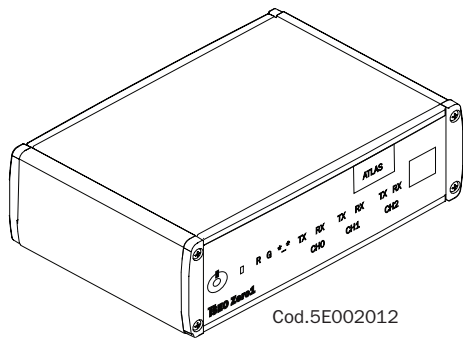

Iseo Serrature s.p.a  
Via San Girolamo 13  
25055 Pisogne (BS)  
ITALIA  
Tel. +39 0364 8821  
iseo@iseo.com

**ELECTRONIC SUPPORT SERVICE**

**iseozero1.com**

Document non contractuel. Sous réserve de modification. Cod. 6000005E00013 - 21/05/2020  
Atlas PLUS Guide d'Installation Guide (FR) - © 2020 Iseo Serrature S.p.a. - www.iseo.com

### AVERTISSEMENTS



- Lire ce manuel avant d'utiliser l'appareil afin d'en garantir une utilisation sûre et appropriée.
- Conserver ce manuel comme référence pour la prochaine fois.
- L'installation et la maintenance de l'appareil doivent être effectuées par un personnel technique qualifié, formé de manière spécifique par l'ISEO.
- Les instructions doivent être soigneusement suivies lors de l'installation. Ces instructions et toute instruction d'entretien doivent être transmises par l'installateur à l'utilisateur.
- Aucune modification de quelque nature que ce soit n'est autorisée, à l'exception de celles décrites dans les présentes instructions.
- Le produit doit être destiné uniquement à l'usage pour lequel il est conçu et donc comme contrôleur de serveur web pour des sites publics et industriels. Toute autre utilisation est considérée comme inappropriée et dangereuse.
- Le raccordement électrique doit être effectué conformément aux instructions du constructeur et dans le respect de la réglementation en vigueur.
- Pour toute réparation, adressez-vous exclusivement à un centre d'assistance technique agréé par le constructeur.
- Débrancher l'alimentation électrique avant d'effectuer une maintenance technique qui implique l'ouverture ou l'accès aux parties internes du produit.
- Jeter le produit séparément des déchets ménagers, conformément aux lois et règlements locaux.
- Le calcul de la longueur des câbles doit être effectué par un personnel qualifié.
- La longueur maximale du câble du circuit LOCKBUS est de 100 mt (somme de tous les câbles).
- La tension recommandée pour le circuit LOCKBUS est de 24 VDC.
- En cas de panne de courant, la batterie rechargeable à l'intérieur de l'Atlas assure une alimentation électrique pendant 30 minutes maximum.
- Assurer la recharge complète de la batterie interne de l'Atlas en effectuant un cycle de recharge complet (24 heures), au minimum tous les 6 mois.
- Il est conseillé de prévoir un disjoncteur approprié, un interrupteur de sécurité en amont du transformateur.
- La connexion à la terre de l'Atlas est obligatoire.
- Ajoutez des dispositifs de sécurité contre les surtensions (SPD) au réseau, en amont de l'Atlas Master, lorsqu'il est connecté à des Atlas Esclaves, des activateurs et des lecteurs placés dans des zones extérieures au bâtiment (zones non équipées), selon l'évaluation des risques de protection contre la foudre de votre bâtiment et les législations en vigueur.
- Pour toute assistance technique ou réparation, contacter uniquement *Iseo Serrature* ou un technicien agréé *Iseo Zero1*.
- *Iseo Zero1* se réserve le droit, sans préavis, d'apporter toutes les modifications nécessaires au produit et au manuel d'instructions, pour des améliorations de la qualité ou des besoins de fabrication ou de commercialisation.



<https://www.iseo.com/it/fr/download>

### ATTENTION

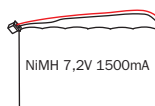

NiMH battery pack  
7,2 V - 1500 mAh



- Risque d'explosion si la batterie est remplacée par un type incorrect. Éliminez les batteries usagées conformément aux règles et lois environnementales locales en vigueur.

## 1. CARACTÉRISTIQUES TECHNIQUES

### Interfaces de communication :

- 1 Interface Ethernet TCP/IP 10/100 base T
- 1 entrée LOCKBUS (CHO) pour connecter lecteurs Stylos et Activateur (max 8 lecteurs et 8 Activateur)
- 2 entrées RS485 (CH1/CH2) pour connecter le lecteur F9000 en ligne (max 1 par canal)
- 1 USB 2.0 Type A
- 1 interface série (débogage)

### Alimentation électrique :

- 12 -24 V D
- Consommation électrique maximale de 10W (sans appareil connecté)

### Batterie de secours interne :

- Batterie NiMH 1500mAh (7,2Vdc)
- Autonomie estimée : 30 min sans alimentation

### CPU et mémoire :

- Module CPU basé sur ARM 9
- Horloge CPU 800MHz
- 512 Mo de mémoire Flash
- 64MB SDRAM
- Micro-SD 8GB

### Système d'exploitation :

- Linux (Kernel 2.6.28)

### Boutons de commande :

- Reset (pour redémarrer manuellement l'Atlas)
- Wake-up (pour redémarrer manuellement l'Atlas lorsqu'il est éteint)
- Switch-OFF (pour éteindre manuellement l'Atlas)

### Boîtier :

- Boîtier d'installation (couleur noire)
- L x Lg x H = 167 x 110 x 53 mm

### Caractéristiques environnementales :

- Température de fonctionnement : 0°C ÷ +50°C
- Température de stockage : -25°C ÷ +75°C

### Certificats de conformité :

- 2014/53/EU RED
- RoHS (electrical and electronic equipment).
- Références standards : EN301 489-1, EN301 489-17, EN330 440, EN60950-1, EN62209-2.
- Pour plus de détails, voir les certificats de conformité disponible sur le site [iseo.com](http://iseo.com) (dans téléchargement).

### Contenu de l'emballage :

- 1 serveur Atlas Plus pour les appareils RFID, F9000 ON-LINE et OFF-LINE, avec connecteurs.
- Alimentation électrique
- Guide d'Installation.

## 2. ATLAS VUE GÉNÉRALE

Connectez-vous au 192.168.0.184 depuis Google Chrome, Microsoft Edge ou Apple Safari.

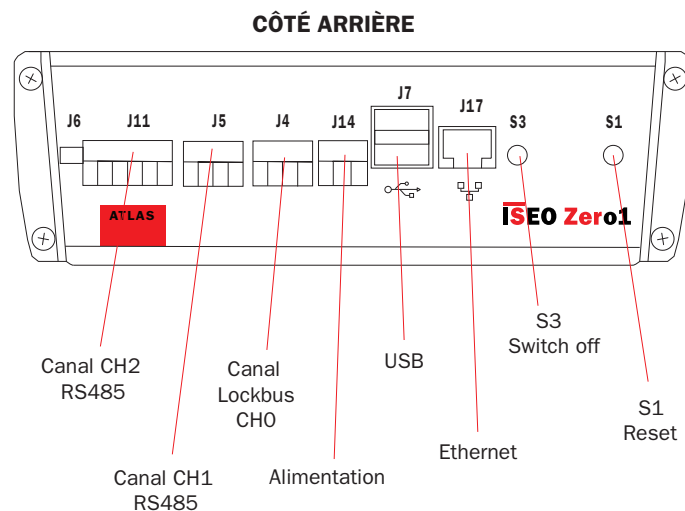
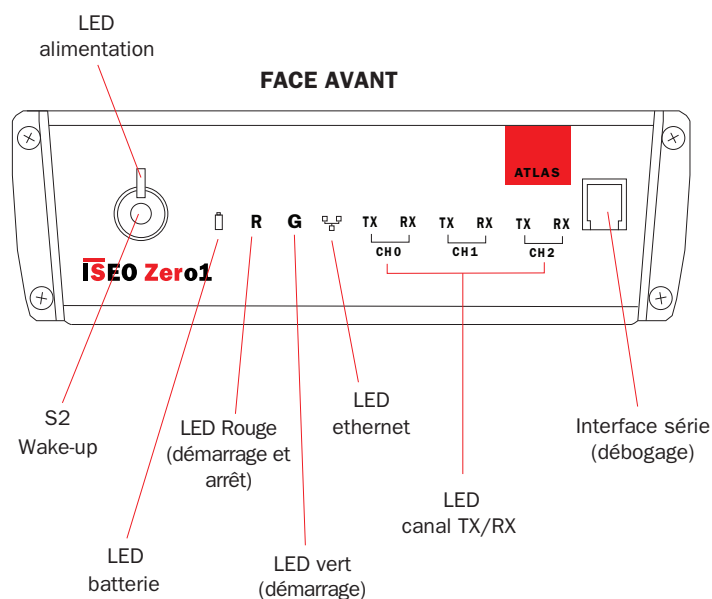

3. CÂBLAGE DU SYSTÈME RFID V364 :  
EXEMPLE DE CONNEXION D'UN CONTRÔLEUR POUR 2 PORTES

CÔTÉ ARRIÈRE

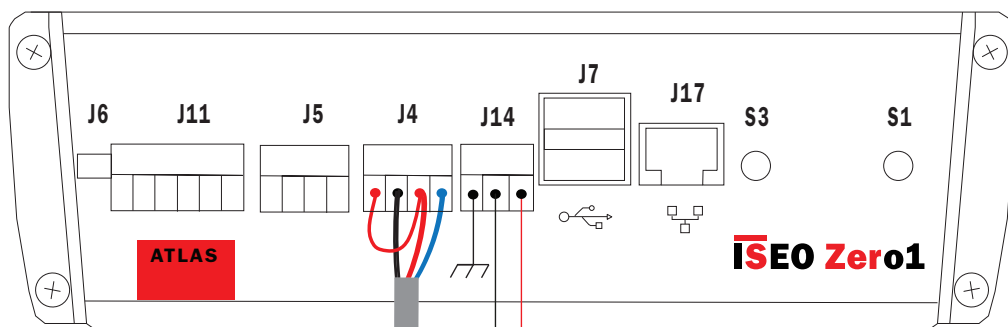

- Configuration conseillée pour le contrôleur 2 portes max 4 lecteurs Stylos.
- Consommation des appareils :
  - ATLAS = 10 W
  - Stylos = 3W
  - Activateur = 3W
- Le câblage s'applique également à la norme Atlas

Alimentation électrique :  
24 VDC - 1,65 A (35 W)

PORTE 1  
(Stylos cod.5E1310126)

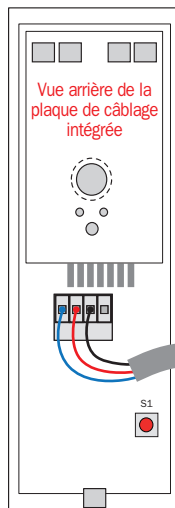

PORTE 1  
(Activateur  
cod.5E2501)

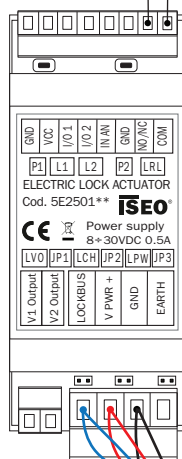

Pour la configuration des lecteurs Stylos consultez le guide d'Installation, disponible à l'adresse suivante : [iseo.com](http://iseo.com).

PORTE 2  
(Stylos cod.5E1310126)

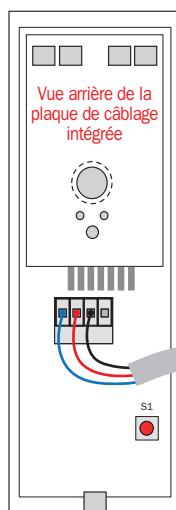

PORTE 2  
(Activateur  
cod.5E2501)

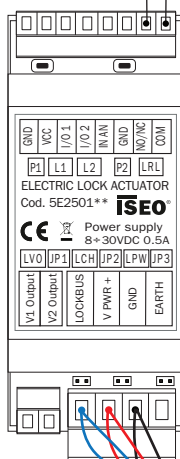

12 VAC

SPÉCIFICATIONS DE CÂBLAGE

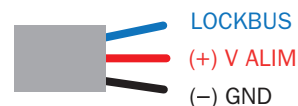

- Câble 3 x 0,75mm - AWG 18 (le calcul de la longueur doit être vérifié par du personnel qualifié).
- Longueur totale du câble du circuit LOCKBUS (somme de tous les câbles) : MAX 100mt.
- Capacité des câbles < 100pF/m.
- Résistance électrique des câbles max 90 ohm/Km.

Les couleurs des fils indiquées dans les schémas de câblage ne sont qu'un exemple.



#### 4. CÂBLAGE DU SYSTÈME V364 F9000 : EXEMPLE DE CONNEXION D'UN CONTRÔLEUR POUR 2 PORTES



- Nombre maximum d'appareils pouvant être connectés au circuit RS485 : 1 (par circuit)
- Consommation des appareils :
  - ATLAS = 10 W
  - Lecteur F9000 = 1W
  - Activateur = 3W
- Le câblage s'applique également à la norme Atlas

CÔTÉ ARRIÈRE

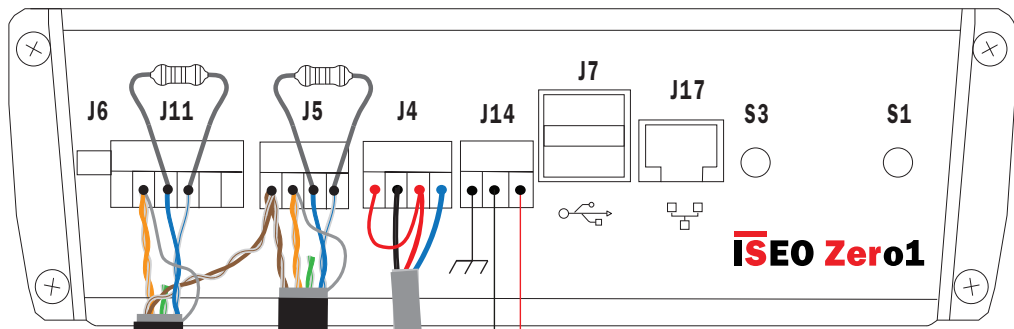

PORTE 2  
(Lecteur F9000  
cod.E032\*\*)

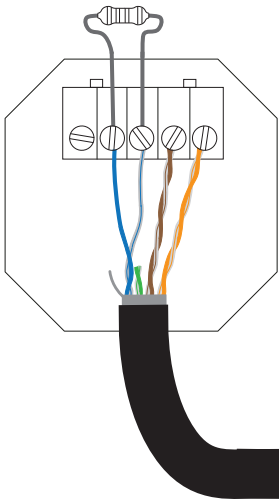

PORTE 1  
(Lecteur F9000  
cod.E032\*\*)

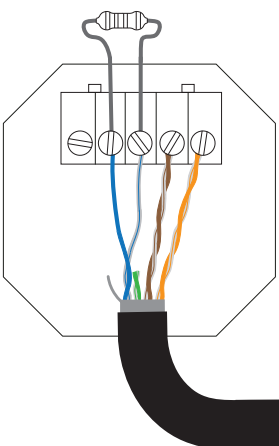

Alimentation électrique :  
24 VDC - 1,65 A  
(35 W)

PORTE 1

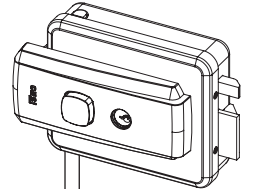

12 VAC

PORTE 1  
(Activateur cod.5E2501)

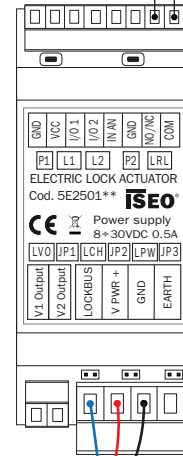

PORTE 2

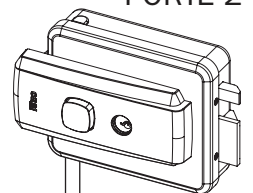

12 VAC

PORTE 2  
(Activateur cod.5E2501)

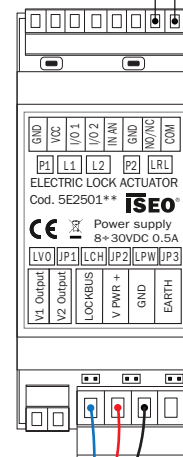

#### SPÉCIFICATIONS DE CÂBLAGE

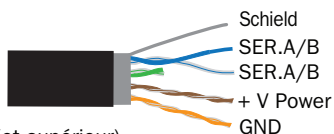

- Câble Ethernet FTP AWG24 CAT5E (et supérieur).
- Longueur maximale du câble Ethernet entre l'Atlas et le lecteur F9000 : 500mt.
- Connecter une batterie de 120 ohms (1/4W), du côté du lecteur Atlas et F9000, comme indiqué dans le schéma.
- Capacité des câbles < 100pF/m.
- Résistance électrique des câbles max 90 ohm/Km.

Les couleurs des fils indiquées dans les schémas de câblage ne sont qu'un exemple.



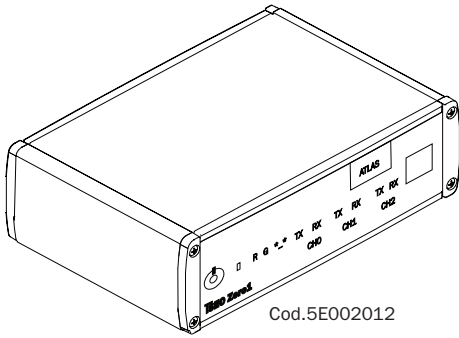

Iseo Serrature s.p.a  
Via San Girolamo 13  
25055 Pisogne (BS)  
ITALIA  
Tel. +39 0364 8821  
iseo@iseo.com

**ELECTRONIC SUPPORT SERVICE**  
**iseozero1.com**

Documento no contractual. Sujeto a cambios. Cod. 6000005E00013 - 21/05/2020  
Atlas DIN Guía de Instalación (ES) - © 2020 Iseo Serrature S.p.a. - www.iseo.com

### ADVERTENCIAS



<https://www.iseo.com/it/es/download>



- Lea este manual antes de utilizar el dispositivo para garantizar un uso seguro y adecuado.
- Conserve este manual como referencia futura.
- La instalación y el mantenimiento del dispositivo deben ser realizados por personal técnico cualificado y debidamente capacitado por ISEO.
- Las instrucciones deben ser cuidadosamente seguidas durante la instalación. El instalador debe facilitar estas instrucciones y las indicaciones de mantenimiento al usuario.
- No se permiten modificaciones de ningún tipo, excepto las descritas en estas instrucciones.
- El producto debe estar destinado únicamente para el uso para el que está expresamente diseñado y, por tanto, como controlador de servidor web para ubicaciones civiles e industriales. Cualquier otro uso se considera impropio y peligroso.
- La conexión eléctrica debe ser realizada de acuerdo con las instrucciones del conductor y respetando la normativa vigente.
- Para todas las reparaciones, comuníquese exclusivamente con un centro de asistencia técnica autorizado por el constructor.
- Desconecte la fuente de alimentación antes de realizar cualquier servicio técnico que implique abrir o acceder a las partes internas del producto.
- Deseche el producto por separado de la basura doméstica, de acuerdo con las leyes y regulaciones en vigor.
- El cálculo de la sección del cableado debe ser realizado por personal cualificado.
- La longitud máxima del cable del canal LOCKBUS es de 100m. (suma de todos los tramos).
- El voltaje recomendado para el canal LOCKBUS es de 24 VCC.
- En caso de fallo de alimentación, la batería recargable interna del Atlas garantiza la alimentación durante un máximo de 30 minutos.
- Garantire la ricarica completa della batteria interna dell'Atlas eseguendo un ciclo di ricarica completo (24 ore), minimo ogni 6 mesi.
- Asegúrese de realizar la carga completa de la batería interna del Atlas, ejecutando un ciclo de recarga completo (24 horas), al menos cada 6 meses.
- La conexión a tierra del Atlas es obligatoria.
- Añada dispositivos de protección contra sobretensiones (SPD) a la red eléctrica, antes del Atlas Master, cuando esté conectado a Atlas Slaves, Actuadores y Lectores ubicados en áreas externas del edificio (zonas no equipotenciales), de acuerdo con la Evaluación de riesgos de protección contra rayos de su edificio y las legislaciones vigentes.
- Para cualquier asistencia o reparaciones, contacte solo a Iseo Serrature o un centro técnico autorizado Iseo Zero1.
- Iseo Zero1 se reserva el derecho, sin previo aviso, de realizar todas las modificaciones necesarias al producto y al manual de instrucciones, para mejoras de calidad, necesidades de fabricación o comercialización.

### ATENCIÓN

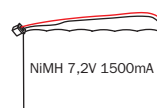

NiMH battery pack  
7,2 V - 1500 mAh



- Riesgo de explosión si la batería es remplazada por una incorrecta. Deseche la batería usada de acuerdo con las leyes y normas ambientales en vigor.

## 1. CARACTERÍSTICAS TÉCNICAS

### Interfaces de comunicación:

- 1 interfaz Ethernet TCP/IP 10/100 base T
- 1 canal LOCKBUS (CH0) para conectar online lectores Stylos y Actuadores (máx. 8 lectores y 8 actuadores).
- 2 canales RS485 (CH1/CH2) para conectar online lectores F9000 (máx. 1 por canal)
- 1 USB 2.0 Tipo A
- 1 interfaz en serie (debug)

### Fuente de alimentación:

- 12÷24 Vcc
- Consumo máximo 10W (sin dispositivos conectados)

### Batería interna de respaldo:

- Paquete de baterías NiMH 1500mAh (7,2Vcc)
- Tiempo estimado de respaldo: 30 minutos

### CPU y memoria:

- Módulo de CPU basado en ARM 9
- Reloj CPU 800MHz
- 512MB de memoria Flash
- 64MB de SDRAM
- 8GB Micro-SD

### Sistema operativo:

- Linux

### Botones:

- S1 Reset (para reiniciar manualmente el Atlas)
- S2 Wake-up (para iniciar manualmente el Atlas cuando está apagado)
- S3 Switch off (para apagar manualmente el Atlas)

### Housing:

- Carcasa (color blanco)
- L x W x H = 167 x 110 x 53 mm

### Características ambientales:

- Temperatura de funcionamiento: 0°C ÷ +50°C
- Temperatura de almacenamiento: -25°C ÷ +75°C

### Certificados de conformidad:

- 2014/53/EU RED
- RoHS (equipos eléctricos y electrónicos).
- Normativa de referencia: EN301 489-1, EN301 489-17, EN330 440, EN60950-1, EN62209-2.
- Para más detalles vea la Declaración de conformidad disponible en el sitio web [iseo.com](http://iseo.com) (área de descarga).

### Contenido del paquete:

- 1 servidor Atlas Plus DIN para dispositivos RFID y F9000 ON-LINE y OFF-LINE, con conectores.
- 1 fuente de alimentación 230Vca/24Vcc - 1,65A (35W)
- Guía de instalación.

## 2. DESCRIPCIÓN DEL ATLAS

Conéctese a **192.168.0.184** desde los navegadores *Google Chrome, Microsoft Edge o Apple Safari.*

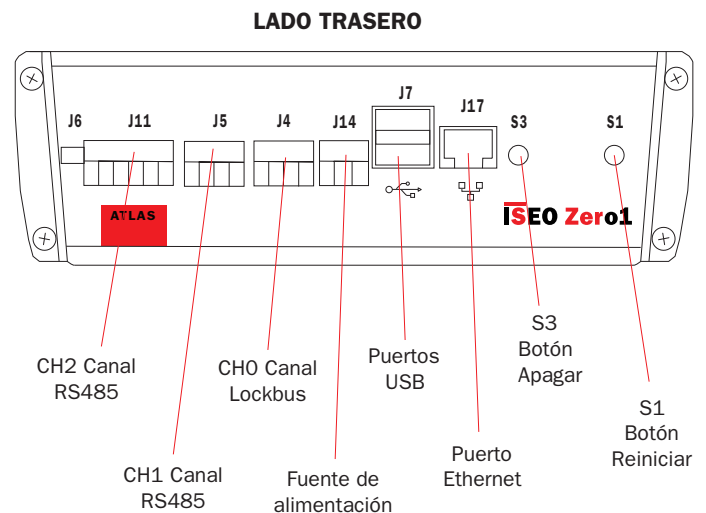
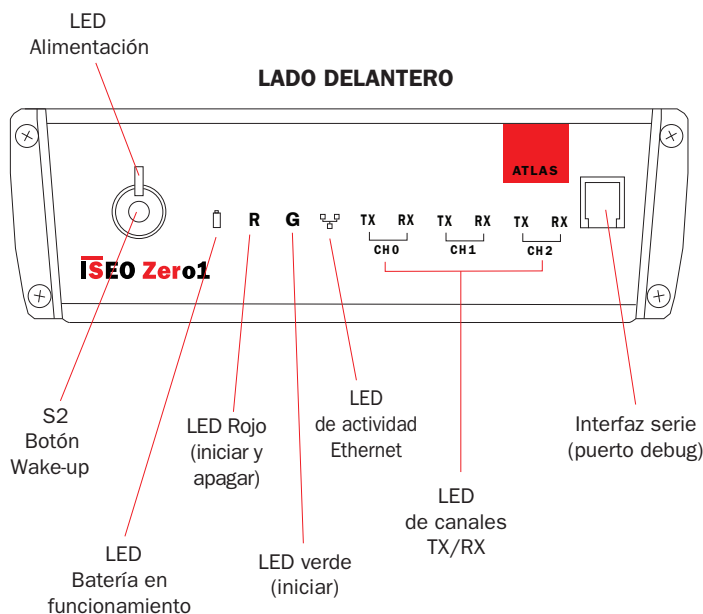

3. CABLEADO DEL SISTEMA V364 RFID:  
EJEMPLO DE CONEXIÓN DEL CONTROLADOR DE PUERTAS

LADO POSTERIOR

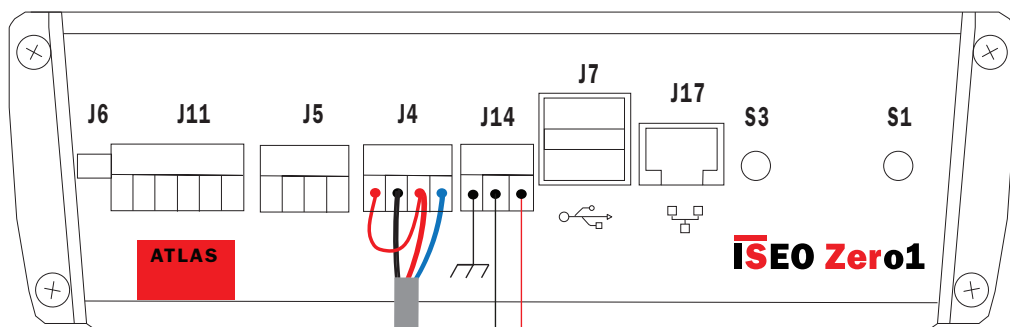

- Configuración sugerida para el controlador de 2 puertas: máx. 4 lectores Stylos.
- Consumo de dispositivos:
  - ATLAS = 10 W
  - Stylos = 3W
  - Actuador = 3W
- Cableado aplicable también al Atlas Standard

Fuente de alimentación:  
24 VDC - 1,65 A (35 W)

PUERTA 1

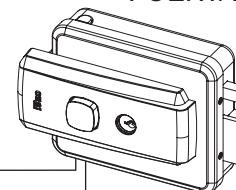

PUERTA 1  
(Stylos cod.5E1310126)

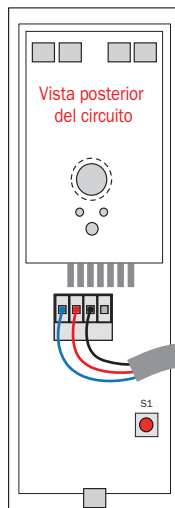

PUERTA 1  
(Actuador  
cod.5E2501)

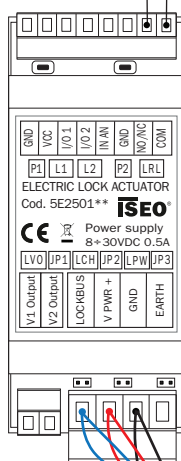

Para la configuración de la dirección del Stylos, consulte la *Guía de instalación de Stylos*, disponible en: [iseo.com](http://iseo.com).

PUERTA 2

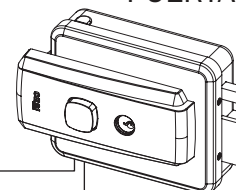

PUERTA 2  
(Stylos cod.5E1310126)

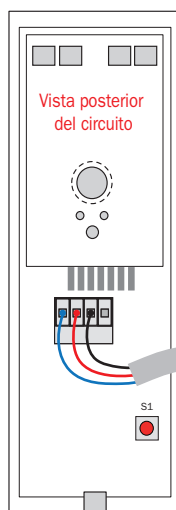

PUERTA 2  
(Actuador  
cod.5E2501)

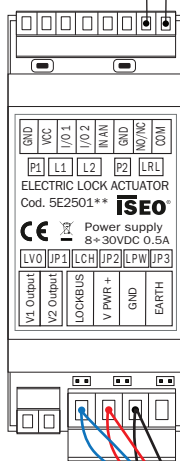

ESPECIFICACIONES DEL CABLEADO

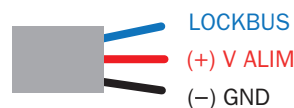

- Cable 3 x 0,75mm<sup>2</sup> - AWG 18 (el cálculo de la sección de cables debe ser verificado por personal cualificado).
- Longitud total del cable del canal LOCKBUS (suma de todos los tramos): MÁX. 100m.
- Capacitancia del conductor < 100pF/m.
- Resistencia eléctrica del conductor máx. 90 ohm/Km.

Los colores de los cables reportados en los diagramas de cableado son solo un ejemplo.

4. CABLEADO DEL SISTEMA V364 F9000:  
EJEMPLO DE CONEXIÓN DEL CONTROLADOR DE 2 PUERTAS

LADO POSTERIOR



- Número máximo de dispositivos que pueden ser conectados al canal RS485 = 1 (por canal).
- Consumo de dispositivos:
  - ATLAS = 10 W
  - Lector F9000 = 1W
  - Actuator = 3W
- Cableado aplicable también al Atlas Standard

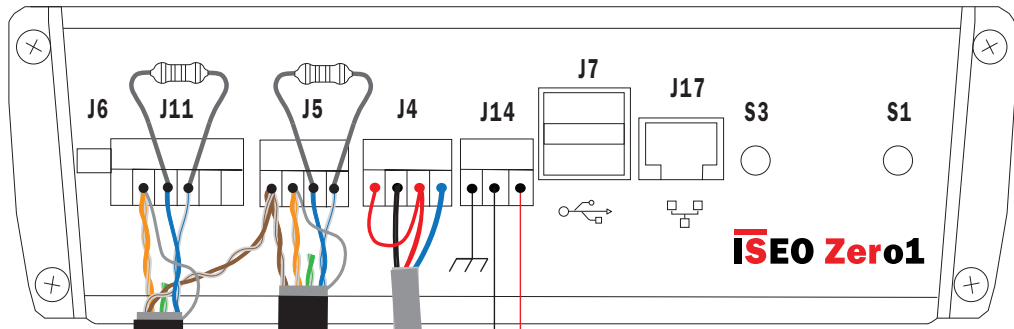

**ISEO Zero1**

PUERTA 1

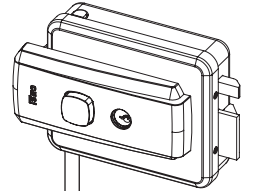

Unidad de fuente de alimentación:  
24 VDC - 1,65 A  
(35 W)

12 VAC



PUERTA 1  
(Actuator cod.5E2501)

PUERTA 2

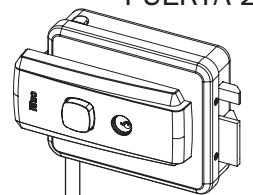

12 VAC

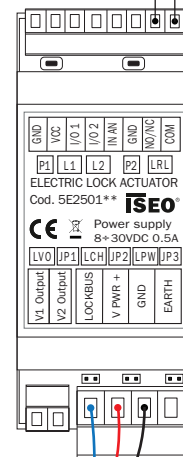

PUERTA 2  
(Actuator cod.5E2501)

PUERTA 2  
(Lector F9000  
cod.E032\*\*)

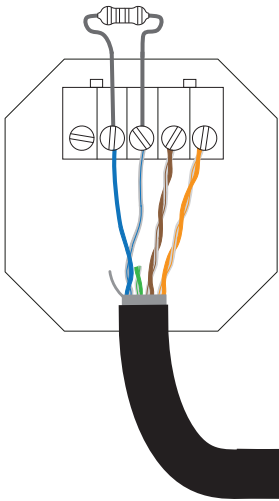

PUERTA 1  
(Lector F9000  
cod.E032\*\*)

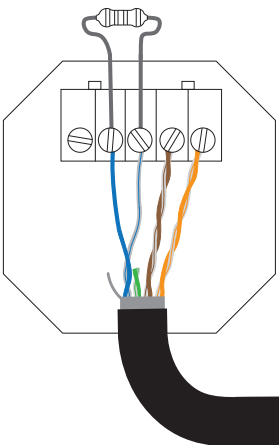

ESPECIFICACIONES DEL CABLEADO

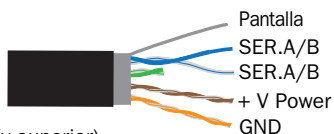

- Cable Ethernet FTP AWG24 CAT5E (y superior).
- Longitud máxima del cable Ethernet entre Atlas y lector F9000: 500m.
- Conecte una resistencia de 120 ohm (1/4W), en ambos lados, Atlas y lector F9000, como se muestra en el esquema.
- Capacitancia del conductor < 100pF/m.
- Resistencia eléctrica del conductor máx. 90 ohm/Km.

Los colores de los cables reportados en los diagramas de cableado son solo un ejemplo.